

Reflex

Systems



ParcelCube 900 SN-1 ParcelCube 900XL SN-1

Capture weights and dimensions of parcels at the click of a button

The complete dimensioning system for use with all inbound and outbound logistics.

- ⚙ Accurate & efficient
- ⚙ Operator friendly PC interface
- ⚙ Reliable & fast data capture
- ⚙ Optimise storage and packing space
- ⚙ Checks all dimensions & weights
- ⚙ Can automatically input measurements into your Warehouse Management or courier system

How does it work?

Simply place the parcel onto the scale, press a button and ParcelCube will capture the dimensions and weights, all data is captured in less than one second - accurately and efficiently!

The ParcelCube includes its own bespoke software and is manufactured for hard working environments. The ParcelCube has all the features required for inbound, outbound and point of sales desk operations.

⚙
Accurate & efficient!
Easy integration!



Software:

Software for ParcelCube has been developed with the user in mind. Simple yet effective, with 7 user defined fields for the data entry of your choice and a calibration function that takes seconds.

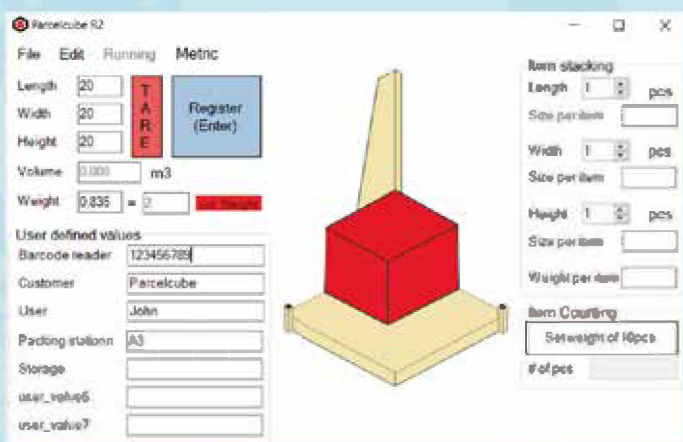

Key Features:

- ⚙️ Helps to optimise warehousing storage
- ⚙️ Easy integration with existing systems
- ⚙️ Multiple fields of information
- ⚙️ Minimises costly input errors
- ⚙️ Time & manpower savings
- ⚙️ Accurate and robust
- ⚙️ Operator friendly
- ⚙️ Improves stock accuracy
- ⚙️ On-site or remote support
- ⚙️ Ensures accurate courier costing



ParcelCube 900 & 900XL SN-1 Specifications

Physical	900 SN-1	900XL SN-1
Dimensions (L x W x H)	68 x 68 x 113cm 26.8 x 26.8 x 44.5in	88 x 88 x 113cm 34.6 x 34.6 x 44.5in
Weight	17.5kg / 35.6lbs	25kg / 55.1lbs
Measuring Capacity		
Minimum (L x W x H)	4 x 4 x 2cm 1.5 x 1.5 x 0.8in	4 x 4 x 2cm 1.5 x 1.5 x 0.8in
Maximum (L x W x H)	62 x 62 x 94cm 24 x 24 x 37in	82 x 82 x 94cm 34 x 34 x 37in
Dimensional Increment	0,1cm / 1,0cm 0,0004 / 0,04in	0,1cm / 1,0cm 0,0004 / 0,04in
Weighing Capacity		
Minimum	0.05kg / 0.11lbs	0.05kg / 0.11lbs
Maximum	55kg / 120lbs	55kg / 120lbs
Increment	0.05kg / 0.11lbs	0.05kg / 0.11lbs
Other		
Power Supply	100 - 240 VAC	100 - 240 VAC
Measuring Sensor	Ultrasonic	Ultrasonic
Weigh Sensor	4 x load cell	4 x load cell
Data Output	CSV / XML / HTTP	CSV / XML / HTTP
User Interface	Windows	Windows
PC Connection	USB	USB
Operating Temperature	+10...+30°C	+10...+30°C

Optional Extras:



ParcelCube Mobile Cart

Make your fixed measuring and packing station portable. The Mobile Cart is ideal for measuring parcels on the move, enabling the need to bring your product to the ParcelCube - take the ParcelCube to your product!



Handheld Barcode Scanner

Scan the barcode with the ParcelCube scanner to automatically capture the details of the parcel you are measuring.



Label Printer

Integrate the ParcelCube with a label printer and BarTender label software so you can automatically print labels with the data captured by the ParcelCube.



Webcam

Installing a webcam to the ParcelCube gives you the facility to photograph each product or parcel you measure. This is particularly useful for double checking incoming and outbound deliveries.



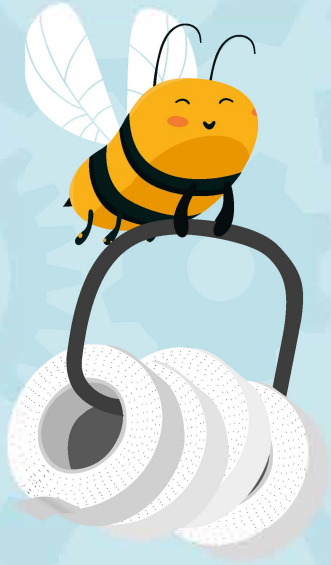

Scan here to find out more



www.reflex-systems.co.uk



☎ 01205 822351

✉ systemsales@reflexlabels.co.uk